



LCD/LED 2748W PV Manual del usuario

- + Deutsch
- + English
- + Français
- + Español
- + Italiano
- + Русский
- + Polski
- + Český
- + 繁體中文
- + 日本語

WORTMANN AG

© WORTMANN AG 2026

Instrucciones de operación

Gracias por comprar este monitor, un monitor color multi-scan de alta resolución. Por favor lea esta guía minuciosamente antes de hacer la instalación.

Este monitor ha sido probado y encontrado en regla el marcado CE. Estos límites están designados para proveer una adecuada protección contra interferencias dañinas de una instalación residencial. Este monitor genera, usa y puede irradiar energía de radio frecuencia. Interferencias dañinas de la radio comunicación pueden seguirse como resultado si este monitor no es instalado y usado propiamente. Sin embargo, no hay garantías de que no ocurrirán interferencias en una particular instalación. Si este monitor causa serias interferencias en la recepción de radio o televisión, reajustar el monitor puede detenerlas. Sin embargo, los usuarios son alentados a corregir las interferencias haciendo una o más de las siguientes cosas:

- Reorientar o reposicionar la antena receptora.
- Mover el monitor y el receptor lejos el uno del otro.
- Conectar el monitor a una toma de corriente en un circuito diferente de aquel al que está conectado el receptor.
- Consultar al vendedor local o a un técnico calificado.

Advertencia:

Para asegurar una continua conformidad, el usuario debe usar un cable enterrado de suministro de la corriente y el cable de interfaz de video provisto con el producto. Además, cualquier cambio no autorizado o modificaciones a este monitor harán vana la autoridad del usuario para operar este mecanismo.

Nota: Si es necesario, cables de interfaz recubiertos y el cable de la corriente deben ser usados cumpliendo con los límites de niveles de emisión.



Base de datos de productos de la UE para la etiqueta energética y la ficha de información del producto

2748W PV : <https://eprel.ec.europa.eu/qr/982568>

Contenido

Precauciones de Seguridad.....	1
Primer Paso.....	2
Instalación Rápida	3
Ilustración que muestra la forma de girar la base del soporte de altura ajustable	5
Vista Frontal del Producto.....	6
Vista Trasera del Producto	7
Usar las Funciones de la Muestra En Pantalla (OSD).....	8
Tiempos soportados	11
Información Técnica.....	12
Mantenimiento y Cuidado	13
Solución de Problemas.....	13

Precauciones de Seguridad

Este monitor ha sido manufacturado y probado bajo el principio de que la seguridad del usuario es lo primero. Sin embargo, el uso o la instalación impropia puede resultar de peligro para el monitor tanto como para el usuario. Lea cuidadosamente las siguientes ADVERTENCIAS antes de la instalación y conserve a mano esta guía.

ADVERTENCIAS:

- ◆ Este monitor debe ser operado solamente según las fuentes de energía indicadas en la etiqueta en la parte trasera del monitor. Si usted no está seguro del suministro de energía en su residencia, consulte a su vendedor local o a la compañía de energía eléctrica.
- ◆ No trate de reparar el monitor por usted mismo cuando esto concierne a partes no ajustables por el usuario. El monitor debe ser reparado solamente por técnicos cualificados.
- ◆ No abra el monitor. Hay partes de alto voltaje adentro que pueden causar un golpe de corriente sobre el cuerpo humano, incluso cuando el cable de la corriente esté desconectado.
- ◆ Antes de encender el monitor, asegúrese de que el cable de alimentación está conectado a una toma de tierra.
- ◆ Si humo, o algún olor o ruido anormal sale de su monitor, desenchúfelo inmediatamente y llame al servicio técnico.
- ◆ Ponga su monitor solamente en un ambiente seco y limpio. Desenchufe el monitor inmediatamente si este se moja y consulte a su servicio técnico.
- ◆ Evite exponer el monitor directamente a la luz del sol o otra fuente de calor.
- ◆ Siempre desenchufe el monitor antes de limpiarlo. Limpie la cobertura con un tela seca y limpia. Aplique limpiadores no basados en amoníacos sobre la tela que usará para limpiar el monitor, nunca directamente sobre el vidrio de la pantalla.
- ◆ Conserve el monitor lejos de objetos magnéticos, motores, televisores, y transformadores de corriente.
- ◆ No coloque objetos pesados sobre los cables del monitor.
- ◆ Para EQUIPOS AÑADIBLES, el enchufe del toma corriente debe estar cerca del equipo y debe ser de fácil acceso.
- ◆ No coloque el monitor sobre en espacio inseguro ya que, si se cae, puede dañarse y provocar lesiones al usuario.
- ◆ Desenchufe el monitor si no lo va a utilizar durante un período prolongado de tiempo.
- ◆ Preste atención a todos los cables conectados al monitor para evitar tropezar con ellos.



Según la regulación WEEE, no se debe desechar este monitor, cuando se torna obsoleto, como una basura común en Europa. Favor refiera a la información de reciclaje de nuestro sitio web para tratarlo.

Primer Paso

¡Felicidades por comprar este monitor de alto rendimiento!

Este monitor viene con los sigtes. accesorios:

- Cable de alimentación de CA
- Tarjeta de Garantía
- Cable DisplayPort
- Guía de inicio Rápido

Instalación Rápida

1. Conecte el cable (DisplayPort)

Asegúrese de que el monitor y el ordenador están APAGADOS.

Conecte el cable DisplayPort desde la salida DisplayPort de la computadora a la entrada DisplayPort del monitor.

O conecte el cable HDMI *Opcional

Conecte el cable HDMI desde la salida HDMI de la computadora a la entrada HDMI del monitor.

O conecte el cable USB-C *Opcional

Conecte el cable USB-C desde la salida USB-C de la computadora a la entrada USB-C del monitor.

Nota importante: El puerto USB-C no admite carga. Utiliza un cable USB-C capaz de transmitir vídeo, asegúrate de que la salida USB-C de tu PC, portátil o tableta admite la transmisión de vídeo y de que están instalados la BIOS y los controladores más recientes.

2. Conecte cable de alimentación

Enchufe el cable que toma la corriente a un toma corriente y después al monitor.

3. Conectar al Audífono (no provisto)

Conecte el audífono al terminal de salida del monitor. (Audífono vendido por separado).

4. ENCENDER ordenador y monitor

Encienda el ordenador, después Encienda el monitor.

5. Usuarios de Windows: Configurar el Modo Cronometraje (Resolución e Índice de Renovar)

Ejemplo: 1920 x 1080 @ 60 Hz

Resolución Clic derecho en el Windows escritorio > Configuración de pantalla > Configuración avanzada de pantalla. Configure la resolución.

Índice de Renovar (frecuencia vertical) Vea la guía de usuario de su tarjeta de gráficas por las instrucciones.

Ejemplo:



Ilustración que muestra la forma de girar la base del soporte de altura ajustable

(1) Ángulo de inclinación

Inclinación hacia ARRIBA: 20°

Inclinación hacia ABAJO: -5°

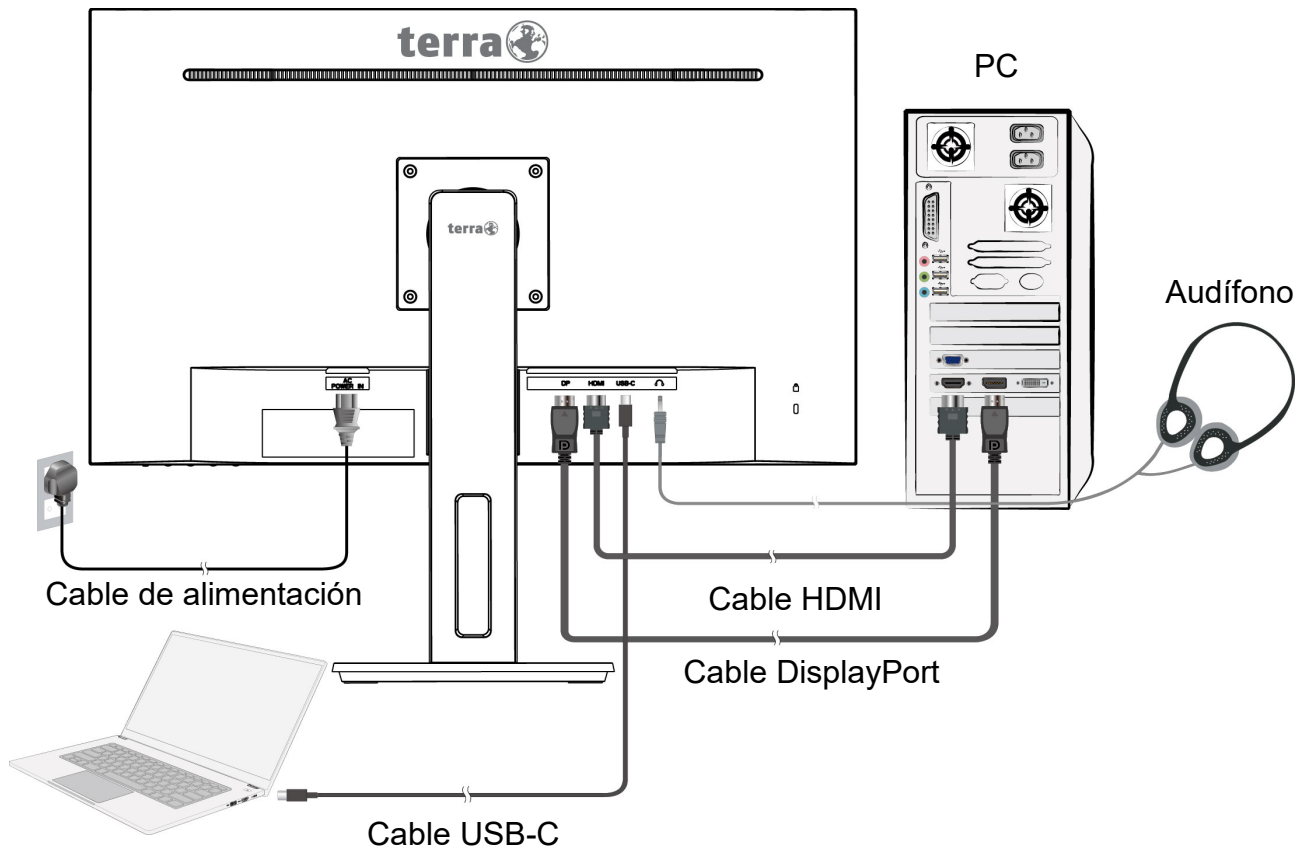
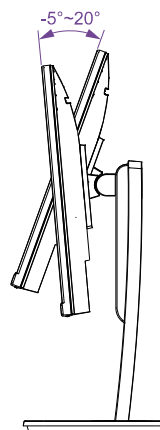

(2) Intervalo de elevación

130mm

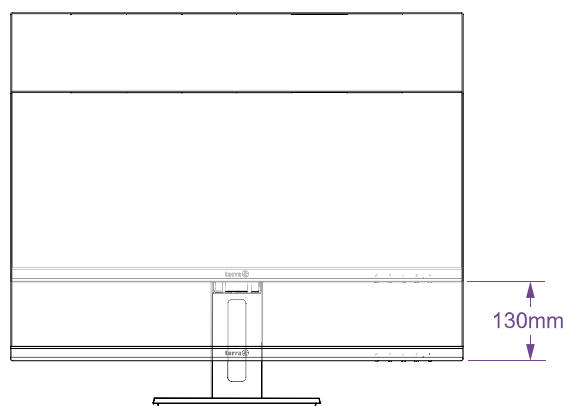

(3) Ángulo de giro

Izquierda: 45°

Derecha: 45°

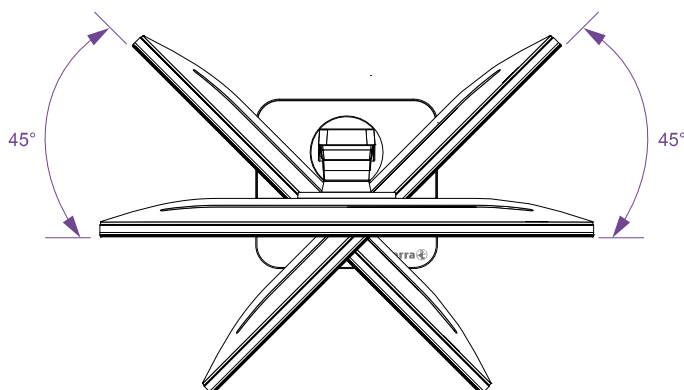

(4) Ángulo de pivote

Derecha: 90°

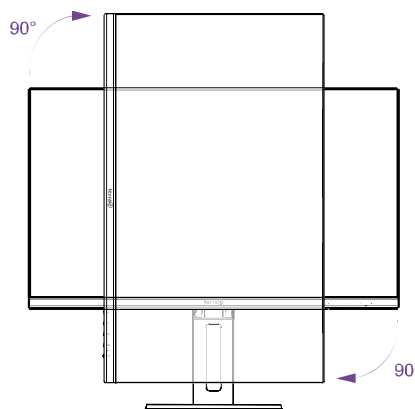

Nota: para evitar un pie rayado. Antes de girar la pantalla, incline la pantalla y después gire la pantalla; posteriormente devuélvala a la posición normal.

Vista Frontal del Producto

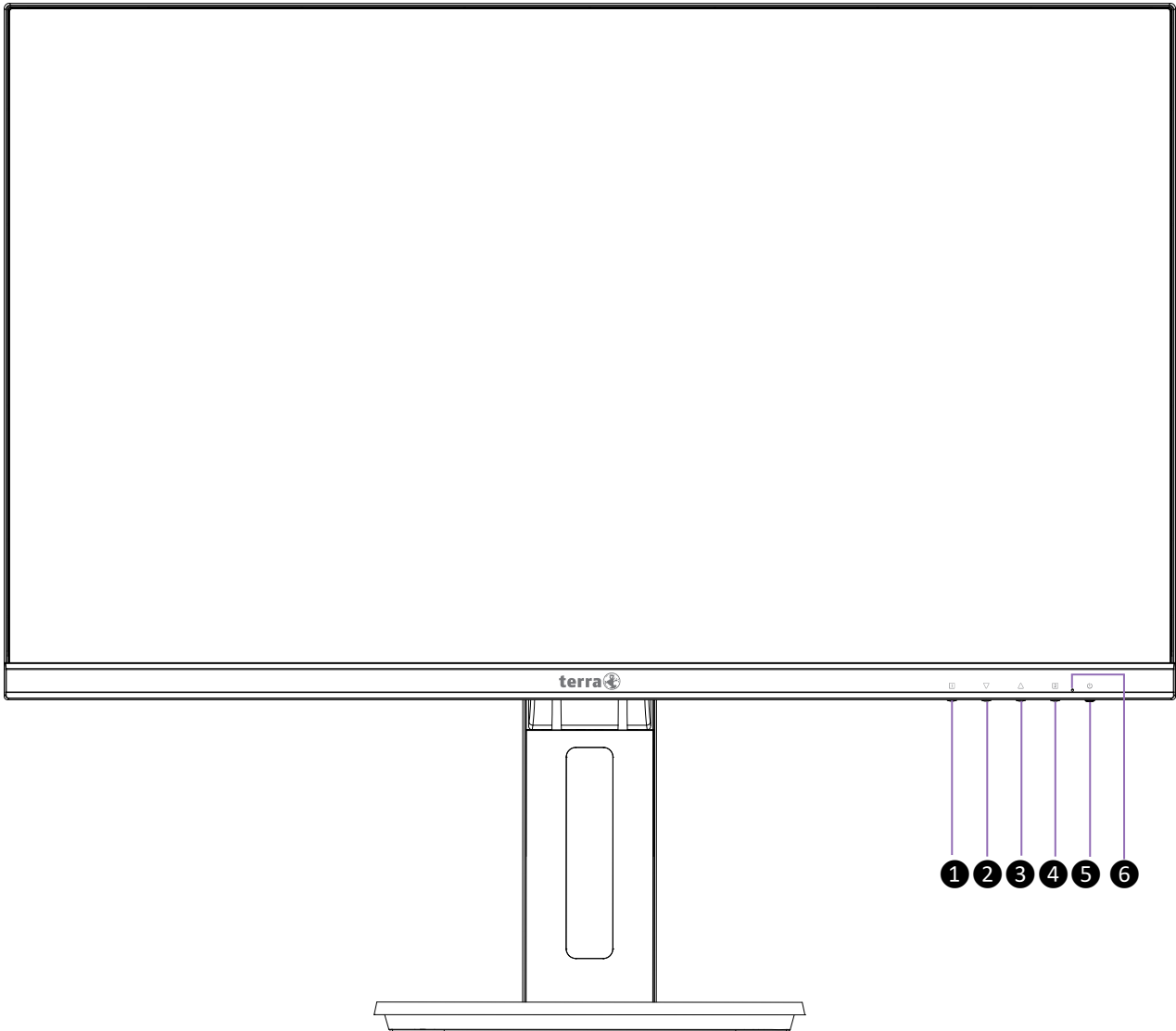

①	Encendido/Apagado del Menú de Muestra En Pantalla
②	Desplazar Abajo/Reducir
③	Desplazar Arriba/Aumentar
④	Confirmar Selección
⑤	Encendido/Apagado
⑥	Indicador LED de Alimentación

Vista Trasera del Producto

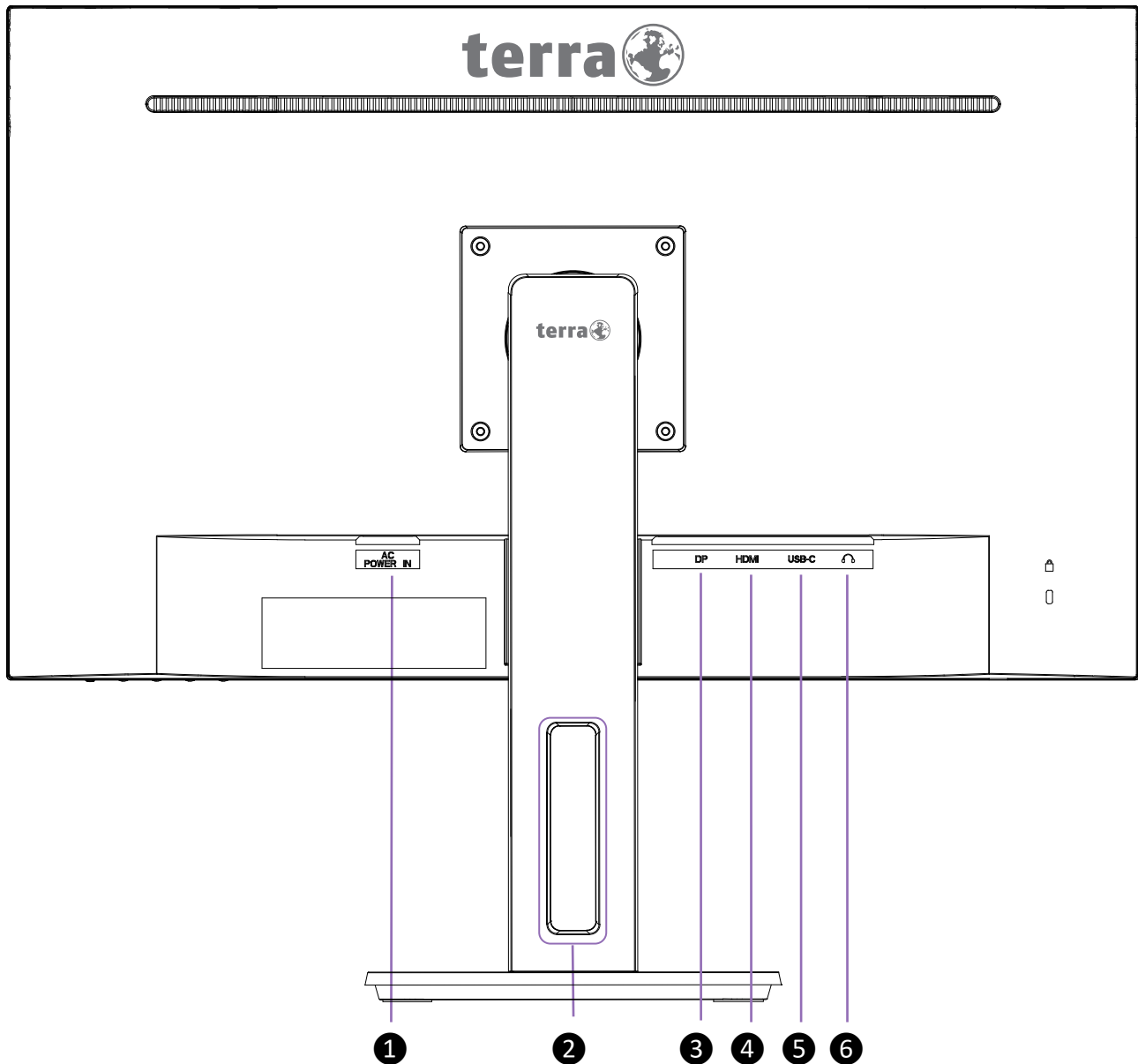

①	Entrada de alimentación
②	Administración de los cables
③	Entrada DisplayPort
④	Entrada HDMI
⑤	Entrada USB-C Nota: El puerto USB-C no admite la carga.
⑥	Salida de Audífono Nota: El ajuste del control de volumen a otros ajustes que no sean la posición central pueden aumentar la salida de potencia de los auriculares/audífonos y por lo tanto el nivel de presión del sonido.

Usar las Funciones de la Muestra En Pantalla (OSD)

1	Muestra el menú principal
	Sale del menú OSD
▲	Selecciona el ítem deseado cuando se encuentra en el menú OSD
	Cuando no está en el menú OSD, ingresa directamente en el menú Volumen
▼	Selecciona el ítem deseado cuando se encuentra en el menú OSD
	Cuando no está en el menú OSD, ingresa directamente en el menú Contraste/Brillo
2	Modo ajuste manual selecciona para modo HDMI, DisplayPort, USB-C
	Confirmar Selección
▲+▼	Vuelve a llamar el Contraste y Brillo (cuando no se encuentra en el menú OSD)
1+▲	Bloquea OSD (cuando no se encuentra en el menú OSD), mantenga pulsado durante 3 segundos
1+▼	Bloquea suministro (cuando no se encuentra en el menú OSD), mantenga pulsado durante 3 segundos

Nota: Cambiar la configuración del menú OSD puede aumentar el consumo de energía.

Menú Principal



Short Cuts Function from the button(s)



Contraste/Brillo: Para regular manualmente los siguientes ajustes de imagen: Contraste, Brillo, DCR, ECO y Over Drive.

- **Contraste:** Para ajustar el nivel de blanco de frente de la imagen de pantalla.
▲: aumentar contraste, ▼: disminuir contraste.
- **Brillo:** Para ajustar la luminancia del vídeo.
▲: aumenta el brillo, ▼: reduce el brillo.
- **DCR:** Para detectar la distribución de las entradas de las señales visuales y conseguir un contraste optimizado. Cuando el DCR está activado se deshabilita el ajuste de Brillo y ECO. Pulse el botón **2** para activar o desactivar DCR.
- **ECO:** Permite al usuario encender y apagar este modo. Cuando el ECO está activado se deshabilita el ajuste de Brillo y DCR. Pulse el botón **2** para activar o desactivar ECO.
- **Over Drive:** Permite al usuario cambiar a la potencia Over Drive. Mejora la calidad de las películas. Pulse el botón **2** para Apagado, 1, 2, o 3 Over Drive.



Selección de entrada: Al oprimir Selección de Entrada cambia la señal de Entrada a HDMI, DisplayPort o USB-C.



Ajuste del sonido: Para ajustar las funciones de audio.

- **Volumen:** Para ajustar el volumen de los altavoces y salida de audífono.



Ajustes de color: Para seleccionar el color para mejorar el brillo y la saturación de color entre Frío, Normal, Caliente, Color de usuario y Modo predeterminado.

- **Frío:** Añade azul a la imagen para hacer el blanco más frío.
- **Normal:** Añade rojo a la imagen para hacer el blanco más cálido y el rojo más rico.
- **Caliente:** Añade verde a la imagen para hacer los colores más oscuros.
- **Color de usuario:** Ajustes individuales para Rojo (R), Verde (V), Azul (A).
1. Pulse el botón **2** para fijar el ajuste y seleccione el siguiente color a ajustar.
2. Pulse ▼ o ▲ para ajustar el color seleccionado.
- **Modo predeterminado:** proporciona un entorno de visualización óptimo dependiendo del contenido visualizado. Consta de 5 preajustes seleccionables por el usuario.

Modo	Descripción / Entorno de visualización óptimo
Estándar	se utiliza para el entorno general de Windows y el ajuste predeterminado del monitor.
Juego	optimiza el entorno de juegos de la PC.
Cinema	optimiza el entorno para películas y vídeo.
Paisaje	optimiza la visualización de imágenes de escenas al aire libre.
Texto	optimiza el entorno de procesamiento de textos para su edición y visualización.



Información: Muestra información acerca de la entrada actual desde la tarjeta gráfica de su ordenador.

Nota: Consulte el manual de su tarjeta gráfica para más información acerca del cambio de resolución y velocidad de fotograma.



Ajuste manual de la: Para ajustar, manualmente, el Nitidez y Ajustar El Modo Vídeo.

- **Nitidez:** Para ajustar la claridad de una señal no Full HD (1920x1080) con el botón ▼ o ▲.
- **Ajustar El Modo Vídeo:** Para seleccionar el modo de vídeo de 4:3 o Pantalla completa.

4:3: Para seleccionar el tamaño de imagen 4:3.

Pantalla completa: Para seleccionar imagen de tamaño de toda la pantalla.



Configuración del menú: Para configurar Idioma, Posición OSD, Temporizador OSD, Imagen de fondo OSD y AMD FreeSync.

- **Idioma:** Permite al usuario escoger entre los idiomas disponibles.
- **Posición OSD:** Oprima el botón ▼ o ▲ para seleccionar entre el ajuste de Posición OSD horizontal y vertical.
 - Posición H.:** Para ajustar horizontalmente la posición OSD.
 - ▲: mueve el OSD a la derecha, ▼: mueve el OSD a la izquierda.
 - Posición V.:** Para ajustar verticalmente la posición OSD.
 - ▲: sube el OSD, ▼: baja el OSD.
- **Temporizador OSD:** Para apagar automáticamente la Muestra En Pantalla (OSD) después de un período de tiempo prefijo.
- **Imagen de fondo OSD:** Activar o desactivar el fondo de la presentación en pantalla.
- **AMD FreeSync:** Para controlar el soporte AMD FreeSync. Pulse el botón **2** para activar o desactivar AMD FreeSync.



Restablecer: Para llamar las configuraciones de fábrica de vuelta para los controles de Vídeo & Audio.

Oprima el botón **2** para seleccionar la opción de menú Memoria.

Tiempos soportados

Especificaciones	Resolución	HDMI	DP	USB Type-C
VGA	720 x 400 @ 70Hz	✓	✓	✓
VGA	640 x 480 @ 60Hz	✓	✓	✓
MAC	640 x 480 @ 67Hz	✓	✓	✓
VESA	640 x 480 @ 72Hz	✓	✓	✓
VESA	640 x 480 @ 75Hz	✓	✓	✓
VESA	800 x 600 @ 56Hz	✓	✓	✓
VESA	800 x 600 @ 60Hz	✓	✓	✓
VESA	800 x 600 @ 72Hz	✓	✓	✓
VESA	800 x 600 @ 75Hz	✓	✓	✓
MAC	832 x 624 @ 75Hz	✓	✓	✓
VESA	1024 x 768 @ 60Hz	✓	✓	✓
VESA	1024 x 768 @ 70Hz	✓	✓	✓
VESA	1024 x 768 @ 75Hz	✓	✓	✓
VESA	1280 x 960 @ 60Hz	✓	✓	✓
VESA	1152 x 864 @ 75Hz	✓	✓	✓
MAC	1152 x 870 @ 75Hz	✓	✓	✓
VESA	1280 x 1024 @ 60Hz	✓	✓	✓
VESA	1280 x 1024 @ 75Hz	✓	✓	✓
VESA	1440 x 900 @ 60Hz	✓	✓	✓
VESA	1440 x 900 @ 75Hz	✓	✓	✓
CVT	1400 x 1050 @ 60Hz	✓	✓	✓
VESA	1600 x 1200 @ 60Hz	✓	✓	✓
VESA	1680 x 1050 @ 60Hz	✓	✓	✓
VESA	1920 x 1080 @ 60Hz	✓	✓	✓
VESA	1920 x 1080 @ 75Hz	✓	✓	✓
VESA	1920 x 1080 @ 100Hz	✓	✓	✓
VESA	1920 x 1080 @ 120Hz	✓	✓	✓
VESA	1920 x 1080 @ 144Hz	✓	✓	✓

* Modos de vídeo

- 480i
- 480p
- 576i
- 576p
- 720p
- 1080i
- 1080p

Aviso: No configure la tarjeta gráfica de su ordenador de forma que exceda estas frecuencias máximas de refresco. Si lo hace podría dañar permanentemente su monitor.

Información Técnica

Especificaciones Técnicas

Panel LCD	68,6 cm (27") (Low Blue Light)
Administración de energía	Compatible con VESA DPMS Modo apagado, ≤ 0,3 W
Resolución Visualizable	Full HD máximo 1920 x 1080. Frecuencia Vertical máxima 144Hz.
Dimensión de Pixel	0,3114 x 0,3114 mm
Color de Muestra LCD	16,7M
Area de Visualización Activa	597.888 x 336.312 mm
Condiciones ambientales	Temperatura Funcionamiento: 0°C a 40°C Almacenamiento: 10% a 90%, sin condensación Humedad Funcionamiento: -20°C a 60°C Almacenamiento: 10% a 90%, sin condensación
Conformidad	CE、UKCA、WEEE、RoHS、VCCI、PSE、PC リサイクル、 J-Moss グリーンマーク
Energía	Input Voltage AC100-240 V
Parlante	3W x 2

Mantenimiento y Cuidado

Cuidado

- Evite exponer el monitor directamente a la luz del sol o otra fuente de calor.
- Coloque su monitor lejos del sol para reducir el deslumbramiento.
- Coloque su monitor en un área bien ventilada. No ponga nada pesado sobre el monitor.
- Asegúrese de que el monitor esté instalado en un área limpia y libre de humedad.
- Mantenga el monitor lejos de imanes, objetos magnéticos, motores, transformadores, parlantes y televisores.

Nota

- Saque el LCD del embalaje y quite la bolsa plástica y la goma esponjosa de poliestireno.
- Ajuste la inclinación de la pantalla para lograr una visión óptima.

Sugerencias de Seguridad

- Si humo, o algún olor o ruido anormal sale de su monitor, desenchúfelo inmediatamente y llame al servicio técnico.
- Nunca quite la cubierta trasera o delantera del monitor. La unidad de visualización de adentro contiene partes de alto voltaje que podrían causar golpes eléctricos sobre el cuerpo humano.
- Nunca trate de reparar su monitor usted mismo. Llame siempre a su servicio técnico o a un técnico cualificado para arreglarlo.

Solución de Problemas

No enciende

- Asegúrese que el cable del monitor esté bien conectado al transformador o adaptador de corriente y este al enchufe de la corriente.
- Enchufe otro electrodoméstico en el mismo enchufe para verificar que el mismo está suministrando un voltaje correcto.
- Asegúrese que todos los cables cortos estén bien instalados.

Encendido pero sin imagen en pantalla

- Asegúrese de que el cable DisplayPort incluido esté bien conectado al puerto de salida de vídeo situado en la parte posterior del ordenador. Si la conexión está floja, apriétela bien.
- Ajuste el brillo.

Colores extraños o anormales

- Si algún color (rojo, verde, azul) están faltando, revise el cable de video para asegurarse que este está bien conectado. Pins sueltos o quebrados en el cable conector podrían causar una conexión impropia o deficiente.
- Conecte el monitor a otra computadora.

Ajuste todos los valores a los valores predeterminados (consulte la función "Restablecer")

WEEE Statement



Wichtige Recyclinginformation

Das Gerät darf nach dem Ende der Nutzungszeit nicht mit dem Restmüll entsorgt werden. Bitte führen Sie es zur umweltgerechten Entsorgung den kommunalen Altgeräte-Sammelstellen zu.

Für weitere Informationen wenden Sie sich bitte an die unten stehende Adresse.

Important Information for Recycling

This warning sign of trash bin indicates that the objects are not allowed to be disposed as general refuse. Please follow the local act and carry out further disposal with refuse recycling and collecting system in your Country or District.

Please contact the address below for more information on recycling.

Informations importantes relatives au recyclage

En fin de vie, cet appareil ne doit pas être jeté aux ordures ménagères.

Veuillez respecter les réglementations locales et rester en conformité avec le système de collecte et de recyclage des ordures en vigueur dans votre région.

Pour plus d'information sur le recyclage, veuillez contacter votre centre de recyclage agréé.

Votre attitude quand au recyclage améliorera l'avenir de la planète et créera un environnement de vie de qualité pour les générations futures.

Wortmann AG

Bredenhop 20

D-32609 Hüllhorst

Tel. +49 (0) 5744 /944-0

Fax +49 (0) 5744 / 944-444

www.wortmann.de

info@wortmann.de



GENERAL PUBLIC LICENSE (GPL) - VER.2

Lizenzinformation Open Source Software/GPL Sourcecode

Dieses Produkt enthält Software, die von Dritten stammt, darunter auch Software, die unter der GNU General Public License Version 2 ("GPLv2") und der GNU Lesser General Public License Version 1.2 (LGPLv2.1) lizenziert ist. Solche Programmbestandteile werden nachfolgend als „Programm“ oder „Program“ bezeichnet.

Schriftliches Angebot des GPL/LGPL Sourcecodes

Wir werden gegen Erstattung der Kosten für den Datenträger und den Versand des Datenträgers auf Nachfrage jedermann den Sourcecode der GPL- und LGPL-Bestandteile der Software auf einer CD-ROM oder einem ähnlichen Datenträger übersenden. Dieses Angebot ist gültig für einen Zeitraum von drei Jahren ab Erwerb des Produktes.

Bei Nachfragen im Zusammenhang mit GPLv2 und LGPLv2.1: Bitte richten Sie alle GPL/LGPL-Nachfragen an die nachfolgend angegebene Adresse. Wir weisen darauf hin, dass unter der angegebenen Adresse kein technischer Support geleistet wird.

LICENSE STATEMENT / GPL CODE STATEMENT

This product includes software code developed by third parties, including software code subject to the GNU General Public License Version 2 ("GPLv2") and the GNU Lesser General Public License, Version 1.2 (LGPLv2.1). These parts of the software are hereinafter referred to as „the or this Program“

WRITTEN OFFER FOR GPL/LGPL SOURCE CODE

We will provide everyone upon request the applicable GPL and LGPL source code files via CD-ROM or similar storage medium for a nominal cost to cover shipping and media charges as allowed under the GPL/LGPL. This offer is valid for 3 years.

GPLv2 and LGPLv2.1 inquiries: Please direct all GPL/LGPL inquiries to the following address. Note that technical support inquiries will not be supported at the below address.

WORTMANN AG
- GPL ANFRAGE -
Bredenhop 20
32609 Hüllhorst
Deutschland

NO WARRANTY

This program is distributed in the hope that it will be useful, but WITHOUT ANY WARRANTY; without even the implied warranty of MERCHANTABILITY or FITNESS FOR A PARTICULAR PURPOSE. See the GNU General Public License for more details.

IN NO EVENT UNLESS REQUIRED BY APPLICABLE LAW OR AGREED TO IN WRITING WILL ANY COPYRIGHT HOLDER, OR ANY OTHER PARTY WHO MAY MODIFY AND/OR REDISTRIBUTE THE PROGRAM AS PERMITTED ABOVE, BE LIABLE TO YOU FOR DAMAGES, INCLUDING ANY GENERAL, SPECIAL, INCIDENTAL OR CONSEQUENTIAL DAMAGES ARISING OUT OF THE USE OR INABILITY TO USE THE PROGRAM (INCLUDING BUT NOT LIMITED TO LOSS OF DATA OR DATA BEING RENDERED INACCURATE OR LOSSES SUSTAINED BY YOU OR THIRD PARTIES OR A FAILURE OF THE PROGRAM TO OPERATE WITH ANY OTHER PROGRAMS), EVEN IF SUCH HOLDER OR OTHER PARTY HAS BEEN ADVISED OF THE POSSIBILITY OF SUCH DAMAGES.

GNU GENERAL PUBLIC LICENSE

Version 2, June 1991

Copyright (C) 1989, 1991 Free Software Foundation, Inc. 51 Franklin Street, Fifth Floor, Boston, MA 02110-1301, USA

Everyone is permitted to copy and distribute verbatim copies of this license document, but changing it is not allowed.

Preamble

The licenses for most software are designed to take away your freedom to share and change it. By contrast, the GNU General Public License is intended to guarantee your freedom to share and change free software--to make sure the software is free for all its users. This General Public License applies to most of the Free Software Foundation's software and to any other program whose authors commit to using it. (Some other Free Software Foundation software is covered by the GNU Lesser General Public License instead.) You can apply it to your programs, too. When we speak of free software, we are referring to freedom, not price. Our General Public Licenses are designed to make sure that you have the freedom to distribute copies of free software (and charge for this service if you wish), that you receive source code or can get it if you want it, that you can change the software or use pieces of it in new free programs; and that you know you can do these things. To protect your rights, we need to make restrictions that forbid anyone to deny you these rights or to ask you to surrender the rights. These restrictions translate to certain responsibilities for you if you distribute copies of the software, or if you modify it. For example, if you distribute copies of such a program, whether gratis or for a fee, you must give the recipients all the rights that you have. You must make sure that they, too, receive or can get the source code. And you must show them these terms so they know their rights.

We protect your rights with two steps: (1) copyright the software, and (2) offer you this license which gives you legal permission to copy, distribute and/or modify the software. Also, for each author's protection and ours, we want to make certain that everyone understands that there is no warranty for this free software. If the software is modified by someone else and passed on, we want its recipients to know that what they have is not the original, so that any problems introduced by others will not reflect on the original authors' reputations. Finally, any free program is threatened constantly by software patents. We wish to avoid the danger that redistributors of a free program will individually obtain patent licenses, in effect making the program proprietary. To prevent this, we have made it clear that any patent must be licensed for everyone's free use or not licensed at all. The precise terms and conditions for copying, distribution and modification follow.

TERMS AND CONDITIONS FOR COPYING, DISTRIBUTION AND MODIFICATION

0. This License applies to any program or other work which contains a notice placed by the copyright holder saying it may be distributed under the terms of this General Public License. The „Program“, below, refers to any such program or work, and a „work based on the Program“ means either the Program or any derivative work under copyright law: that is to say, a work containing the Program or a portion of it, either verbatim or with modifications and/or translated into another language. (Hereinafter, translation is included without limitation in the term „modification“.) Each licensee is addressed as „you“. Activities other than copying, distribution and modification are not covered by this License; they are outside its scope. The act of running the Program is not restricted, and the output from the Program is covered only if its contents constitute a work based on the Program (independent of having been made by running the Program). Whether that is true depends on what the Program does.

1. You may copy and distribute verbatim copies of the Program's source code as you receive it, in any medium, provided that you conspicuously and appropriately publish on each copy an appropriate copyright notice and disclaimer of warranty; keep intact all the notices that refer to this License and to the absence of any warranty; and give any other recipients of the Program a copy of this License along with the Program.

You may charge a fee for the physical act of transferring a copy, and you may at your option offer warranty protection in exchange for a fee.

2. You may modify your copy or copies of the Program or any portion of it, thus forming a work based on the Program, and copy and distribute such modifications or work under the terms of Section 1 above, provided that you also meet all of these conditions:

a) You must cause the modified files to carry prominent notices stating that you changed the files and the date of any change.

b) You must cause any work that you distribute or publish, that in whole or in part contains or is derived from the Program or any part thereof, to be licensed as a whole at no charge to all third parties under the terms of this License.

c) If the modified program normally reads commands interactively when run, you must cause it, when started running for such interactive use in the most ordinary way, to print or display an announcement including an appropriate copyright notice and a notice that there is no warranty (or else, saying that you provide a warranty) and that users may redistribute the program under these conditions, and telling the user how to view a copy of this License. (Exception: if the Program itself is interactive but does not normally print such an announcement, your work based on the Program is not required to print an announcement.)

These requirements apply to the modified work as a whole. If identifiable sections of that work are not derived from the Program, and can be reasonably considered independent and separate works in themselves, then this License, and its terms, do not apply to those sections when you distribute them as separate works. But when you distribute the same sections as part of a whole which is a work based on the Program, the distribution of the whole must be on the terms of this License, whose permissions for other licensees extend to the entire whole, and thus to each and every part regardless of who wrote it.

Thus, it is not the intent of this section to claim rights or contest your rights to work written entirely by you; rather, the intent is to exercise the right to control the distribution of derivative or collective works based on the Program.

In addition, mere aggregation of another work not based on the Program with the Program (or

with a work based on the Program) on a volume of a storage or distribution medium does not bring the other work under the scope of this License.

3. You may copy and distribute the Program (or a work based on it, under Section 2) in object code or executable form under the terms of Sections 1 and 2 above provided that you also do one of the following:

we use this doubled UL to get the sub-sections indented, while making the bullets as unobvious as possible.

a) Accompany it with the complete corresponding machine-readable source code, which must be distributed under the terms of Sections 1 and 2 above on a medium customarily used for software interchange; or,

b) Accompany it with a written offer, valid for at least three years, to give any third party, for a charge no more than your cost of physically performing source distribution, a complete machine-readable copy of the corresponding source code, to be distributed under the terms of Sections 1 and 2 above on a medium customarily used for software interchange; or,

c) Accompany it with the information you received as to the offer to distribute corresponding source code. (This alternative is allowed only for noncommercial distribution and only if you received the program in object code or executable form with such an offer, in accord with Sub-section b above.) The source code for a work means the preferred form of the work for making modifications to it. For an executable work, complete source code means all the source code for all modules it contains, plus any associated interface definition files, plus the scripts used to control compilation and installation of the executable. However, as a special exception, the source code distributed need not include anything that is normally distributed (in either source or binary form) with the major components (compiler, kernel, and so on) of the operating system on which the executable runs, unless that component itself accompanies the executable. If distribution of executable or object code is made by offering access to copy from a designated place, then offering equivalent access to copy the source code from the same place counts as distribution of the source code, even though third parties are not compelled to copy the source along with the object code.

4. You may not copy, modify, sublicense, or distribute the Program except as expressly provided under this License. Any attempt otherwise to copy, modify, sublicense or distribute the Program is void, and will automatically terminate your rights under this License. However, parties who have received copies, or rights, from you under this License will not have their licenses terminated so long as such parties remain in full compliance.

5. You are not required to accept this License, since you have not signed it. However, nothing else grants you permission to modify or distribute the Program or its derivative works. These actions are prohibited by law if you do not accept this License. Therefore, by modifying or distributing the Program (or any work based on the Program), you indicate your acceptance of this License to do so, and all its terms and conditions for copying, distributing or modifying the Program or works based on it.

6. Each time you redistribute the Program (or any work based on the Program), the recipient automatically receives a license from the original licensor to copy, distribute or modify the Program subject to these terms and conditions. You may not impose any further restrictions on the recipients' exercise of the rights granted herein. You are not responsible for enforcing compliance by third parties to this License.

7. If, as a consequence of a court judgment or allegation of patent infringement or for any other reason (not limited to patent issues), conditions are imposed on you (whether by court order, agreement or otherwise) that contradict the conditions of this License, they do not excuse you from the conditions of this License. If you cannot distribute so as to satisfy simultaneously your obligations under this License and any other pertinent obligations, then as a consequence you may not distribute the Program at all. For example, if a patent license would not permit royalty-free redistribution of the Program by all those who receive copies directly or indirectly through you, then the only way you could satisfy both it and this License would be to refrain entirely from distribution of the Program.

If any portion of this section is held invalid or unenforceable under any particular circumstance, the balance of the section is intended to apply and the section as a whole is intended to apply in other circumstances.

It is not the purpose of this section to induce you to infringe any patents or other property right claims or to contest validity of any such claims; this section has the sole purpose of protecting the integrity of the free software distribution system, which is implemented by public license practices. Many people have made generous contributions to the wide range of software distributed through that system in reliance on consistent application of that system; it is up to the author/donor to decide if he or she is willing to distribute software through any other system and a licensee cannot impose that choice. This section is intended to make thoroughly clear what is believed to be a consequence of the rest of this License.

8. If the distribution and/or use of the Program is restricted in certain countries either by patents or by copyrighted interfaces, the original copyright holder who places the Program under this License may add an explicit geographical distribution limitation excluding those countries, so that distribution is permitted only in or among countries not thus excluded. In such case, this License incorporates the limitation as if written in the body of this License.

9. The Free Software Foundation may publish revised and/or new versions of the General Public License from time to time. Such new versions will be similar in spirit to the present version, but may differ in detail to address new problems or concerns. Each version is given a distinguishing version number. If the Program specifies a version number of this License which applies to it and „any later version“, you have the option of following the terms and conditions either of that version or of any later version published by the Free Software Foundation. If the Program does not specify a version number of this License, you may choose any version ever published by the Free Software Foundation.

10. If you wish to incorporate parts of the Program into other free programs whose distribution conditions are different, write to the author to ask for permission. For software which is copyrighted by the Free Software Foundation, write to the Free Software Foundation; we sometimes make exceptions for this. Our decision will be guided by the two goals of preserving the free status of all derivatives of our free software and of promoting the sharing and reuse of software generally.

NO WARRANTY

11. BECAUSE THE PROGRAM IS LICENSED FREE OF CHARGE, THERE IS NO WARRANTY FOR THE PROGRAM, TO THE EXTENT PERMITTED BY APPLICABLE LAW. EXCEPT WHEN OTHERWISE STATED IN WRITING THE COPYRIGHT HOLDERS AND/OR OTHER PARTIES PROVIDE THE PROGRAM „AS IS“ WITHOUT WARRANTY OF ANY KIND, EITHER EXPRESSED OR IMPLIED, INCLUDING, BUT NOT LIMITED TO, THE IMPLIED WARRANTIES OF MERCHANTABILITY AND FITNESS FOR A PARTICULAR PURPOSE. THE ENTIRE RISK AS TO THE QUALITY AND PERFORMANCE OF THE PROGRAM IS WITH YOU. SHOULD THE PROGRAM PROVE DEFECTIVE, YOU ASSUME THE COST OF ALL NECESSARY SERVICING, REPAIR OR CORRECTION.

12. IN NO EVENT UNLESS REQUIRED BY APPLICABLE LAW OR AGREED TO IN WRITING WILL ANY COPYRIGHT HOLDER, OR ANY OTHER PARTY WHO MAY MODIFY AND/OR REDISTRIBUTE THE PROGRAM AS PERMITTED ABOVE, BE LIABLE TO YOU FOR DAMAGES, INCLUDING ANY GENERAL, SPECIAL, INCIDENTAL OR CONSEQUENTIAL DAMAGES ARISING OUT OF THE USE OR INABILITY TO USE THE PROGRAM (INCLUDING BUT NOT LIMITED TO LOSS OF DATA OR DATA BEING RENDERED INACCURATE OR LOSSES SUSTAINED BY YOU OR THIRD PARTIES OR A FAILURE OF THE PROGRAM TO OPERATE WITH ANY OTHER PROGRAMS), EVEN IF SUCH HOLDER OR OTHER PARTY HAS BEEN ADVISED OF THE POSSIBILITY OF SUCH DAMAGES.

END OF TERMS AND CONDITIONS

How to Apply These Terms to Your New Programs

If you develop a new program, and you want it to be of the greatest possible use to the public, the best way to achieve this is to make it free software which everyone can redistribute and change under these terms.

To do so, attach the following notices to the program. It is safest to attach them to the start of each source file to most effectively state the exclusion of warranty; and each file should have at least the "copyright" line and a pointer to where the full notice is found.

```
<one line to give the program's name and a brief idea of what it does.>
Copyright (C) <year> <name of author>
```

This program is free software: you can redistribute it and/or modify it under the terms of the GNU General Public License as published by the Free Software Foundation, either version 3 of the License, or (at your option) any later version.

This program is distributed in the hope that it will be useful, but WITHOUT ANY WARRANTY; without even the implied warranty of MERCHANTABILITY or FITNESS FOR A PARTICULAR PURPOSE. See the GNU General Public License for more details.

You should have received a copy of the GNU General Public License along with this program. If not, see <<http://www.gnu.org/licenses/>>.

Also add information on how to contact you by electronic and paper mail.

If the program does terminal interaction, make it output a short notice like this when it starts in an interactive mode:

```
<program> Copyright (C) <year> <name of author>
This program comes with ABSOLUTELY NO WARRANTY; for details type `show w`.
This is free software, and you are welcome to redistribute it under certain conditions;
type `show c` for details.
```

The hypothetical commands `show w` and `show c` should show the appropriate parts of the General Public License. Of course, your program's commands might be different; for a GUI interface, you would use an "about box".

You should also get your employer (if you work as a programmer) or school, if any, to sign a "copyright disclaimer" for the program, if necessary. For more information on this, and how to apply and follow the GNU GPL, see <<http://www.gnu.org/licenses/>>.

The GNU General Public License does not permit incorporating your program into proprietary programs. If your program is a subroutine library, you may consider it more useful to permit linking proprietary applications with the library. If this is what you want to do, use the GNU Lesser General Public License instead of this License. But first, please read <<http://www.gnu.org/philosophy/why-not-lgpl.html>>

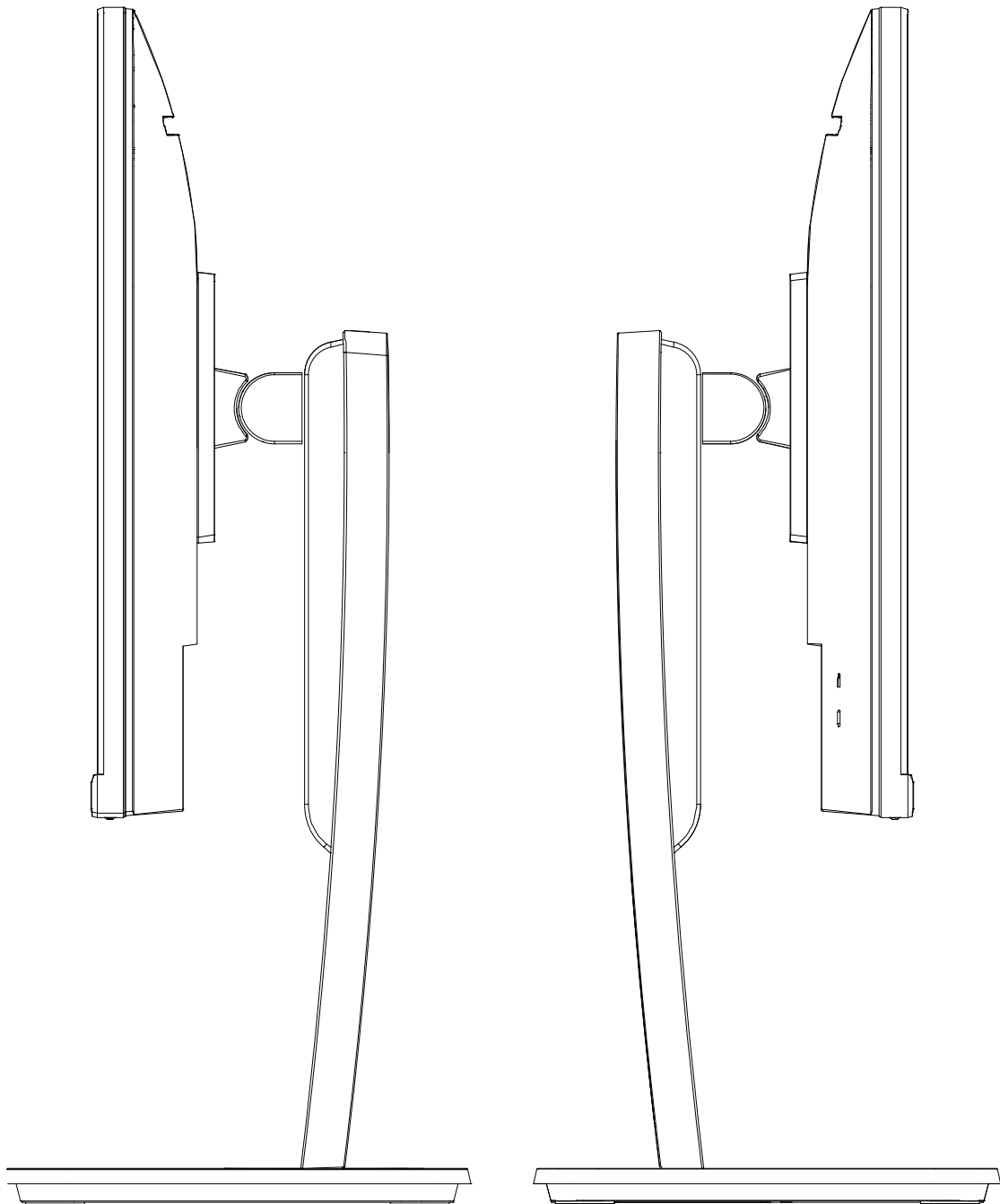

Bredenhop 20_32609 Hüllhorst
Tel +49 5744.944-0_Fax +49 5744.944-100
www.wortmann.de